

# ADC1006S055/070

Single 10 bits ADC, up to 55 MHz or 70 MHz

Rev. 02 — 12 August 2008

Product data sheet

## 1. General description

---

The ADC1006S055/070 are a family of Bipolar CMOS (BiCMOS) 10-bit Analog-to-Digital Converters (ADC) optimized for a wide range of applications such as cellular infrastructures, professional telecommunications, imaging, and digital radio. It converts the analog input signal into 10-bit binary coded digital words at a maximum sampling rate of 70 MHz. All static digital inputs (SH,  $\overline{CE}$  and OTC) are Transistor-Transistor Logic (TTL) and CMOS compatible and all outputs are CMOS compatible. A sine wave clock input signal can also be used.

## 2. Features

---

- 10-bit resolution
- Sampling rate up to 70 MHz
- -3 dB bandwidth of 245 MHz
- 5 V power supplies and 3.3 V output power supply
- Binary or two's complement CMOS outputs
- In-range CMOS compatible output
- TTL and CMOS compatible static digital inputs
- TTL and CMOS compatible digital outputs
- Differential AC or Positive Emitter-Coupled Logic (PECL) clock input; TTL compatible
- Power dissipation 550 mW (typical)
- Low analog input capacitance (typical 2 pF), no buffer amplifier required
- Integrated sample-and-hold amplifier
- Differential analog input
- External amplitude range control
- Voltage controlled regulator included
- -40 °C to +85 °C ambient temperature

## 3. Applications

---

High-speed analog-to-digital conversion for:

- Cellular infrastructure
- Professional telecommunication
- Digital radio
- Radar
- Medical imaging
- Fixed network
- Cable modem

- Barcode scanner
- Cable Modem Termination System (CMTS)/Data Over Cable Service Interface Specification (DOCSIS)

## 4. Quick reference data

**Table 1. Quick reference data**

$V_{CCA} = V2$  to  $V44$ ,  $V3$  to  $V4$  and  $V41$  to  $V40 = 4.75$  V to  $5.25$  V;  $V_{CCD} = V37$  to  $V38$  and  $V15$  to  $V17 = 4.75$  V to  $5.25$  V;  $V_{CCO} = V33$  to  $V34 = 3.0$  V to  $3.6$  V; AGND and DGND shorted together;  $T_{amb} = -40$  °C to  $+85$  °C;  $V_{I(IN)(p-p)} - V_{I(INN)(p-p)} = 1.9$  V;  $V_{VREF} = V_{CCA3} - 1.75$  V;  $V_{I(cm)} = V_{CCA3} - 1.6$  V; typical values measured at  $V_{CCA} = V_{CCD} = 5$  V and  $V_{CCO} = 3.3$  V,  $T_{amb} = 25$  °C and  $C_L = 10$  pF; unless otherwise specified.

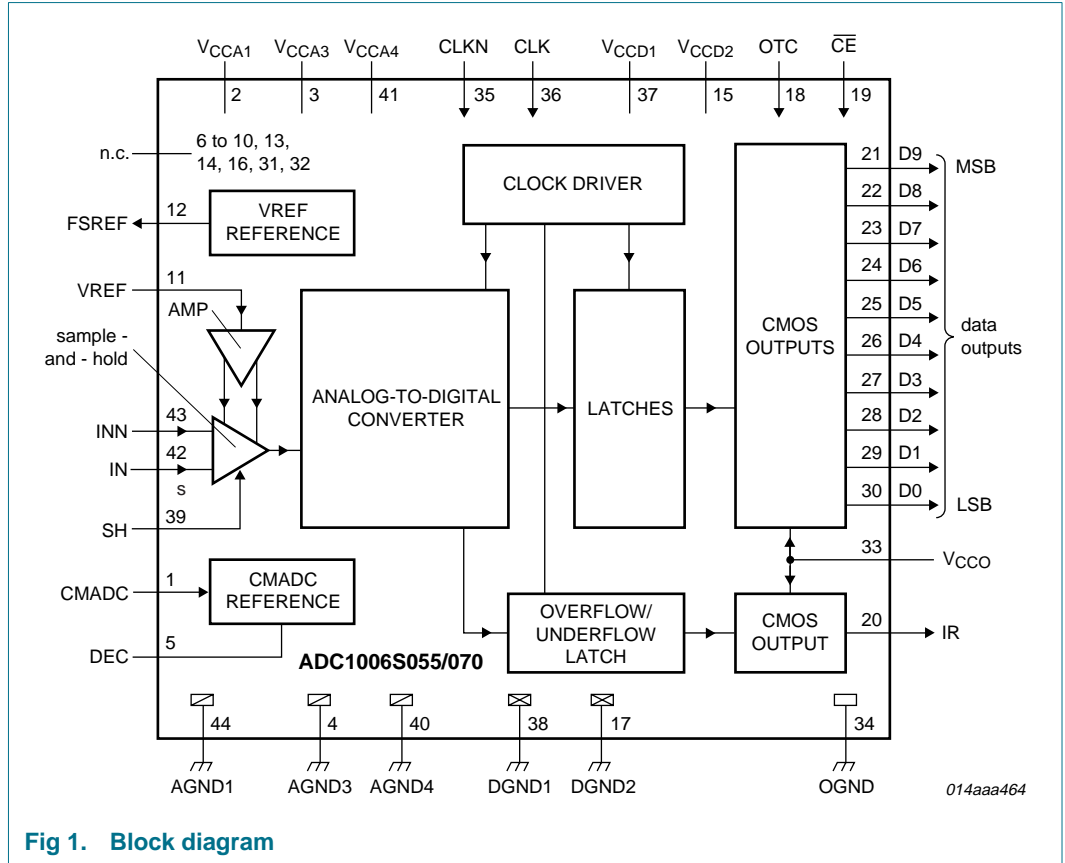
Symbol	Parameter	Conditions	Min	Typ	Max	Unit
$V_{CCA}$	analog supply voltage		4.75	5.0	5.25	V
$V_{CCD}$	digital supply voltage		4.75	5.0	5.25	V
$V_{CCO}$	output supply voltage		3.0	3.3	3.6	V
$I_{CCA}$	analog supply current		-	78	87	mA
$I_{CCD}$	digital supply current		-	27	30	mA
$I_{CCO}$	output supply current	$f_{clk} = 20$ MHz; $f_i = 400$ kHz	-	3	4	mA
INL	integral non-linearity	$f_{clk} = 20$ MHz; $f_i = 400$ kHz	-	$\pm 0.65$	$\pm 1.12$	LSB
DNL	differential non-linearity	$f_{clk} = 20$ MHz; $f_i = 400$ kHz (no missing code guaranteed)	-	$\pm 0.12$	$\pm 0.27$	LSB
$f_{clk(max)}$	maximum clock frequency	ADC1006S055H	55	-	-	MHz
		ADC1006S070H	70	-	-	MHz
$P_{tot}$	total power dissipation	$f_{clk} = 55$ MHz; $f_i = 20$ MHz	-	550	660	mW

## 5. Ordering information

**Table 2. Ordering information**

Type number	Package			Sampling frequency (MHz)
	Name	Description	Version	
ADC1006S055H	QFP44	plastic quad flat package; 44 leads (lead length 1.3 mm); body 10 × 10 × 1.75 mm	SOT307-2	55
ADC1006S070H	QFP44	plastic quad flat package; 44 leads (lead length 1.3 mm); body 10 × 10 × 1.75 mm	SOT307-2	70

**6. Block diagram**



**Fig 1. Block diagram**

## 7. Pinning information

### 7.1 Pinning

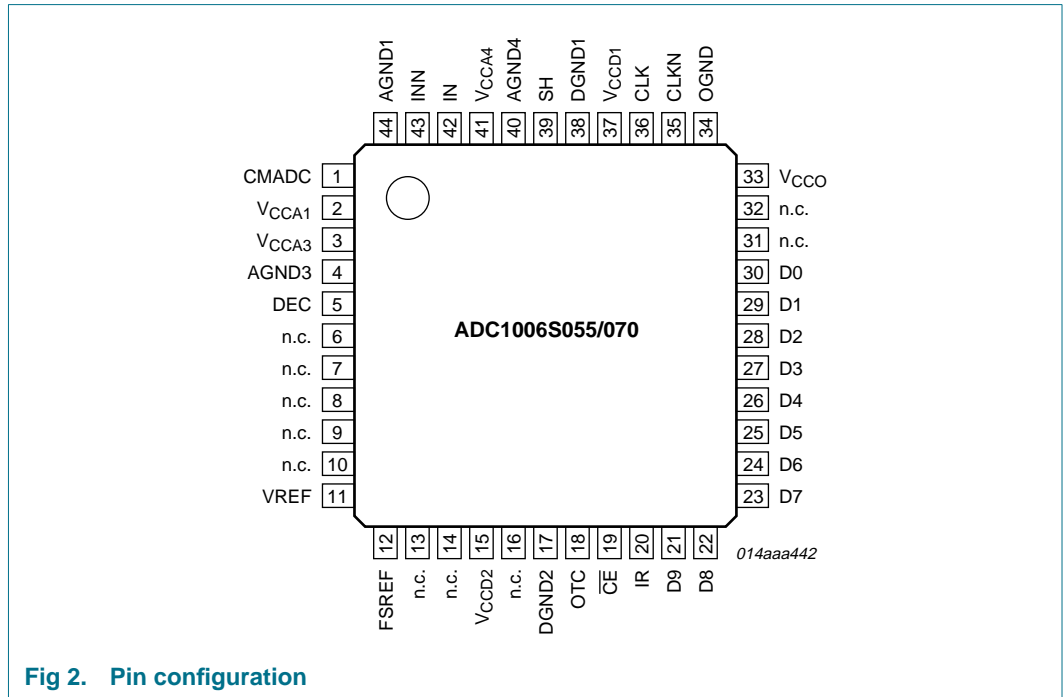


Fig 2. Pin configuration

### 7.2 Pin description

Table 3. Pin description

Symbol	Pin	Description
CMADC	1	regulator output common mode ADC input
V <sub>CCA1</sub>	2	analog supply voltage 1 (5 V)
V <sub>CCA3</sub>	3	analog supply voltage 3 (5 V)
AGND3	4	analog ground 3
DEC	5	decoupling node
n.c.	6	not connected
n.c.	7	not connected
n.c.	8	not connected
n.c.	9	not connected
n.c.	10	not connected
VREF	11	reference voltage input
FSREF	12	full-scale reference output
n.c.	13	not connected
n.c.	14	not connected
V <sub>CCD2</sub>	15	digital supply voltage 2 (5 V)
n.c.	16	not connected
DGND2	17	digital ground 2

**Table 3.** Pin description ...continued

Symbol	Pin	Description
OTC	18	control input two's complement output; active HIGH
$\overline{CE}$	19	chip enable input (CMOS level; active LOW)
IR	20	in-range output
D9	21	data output; bit 9 (Most Significant Bit (MSB))
D8	22	data output; bit 8
D7	23	data output; bit 7
D6	24	data output; bit 6
D5	25	data output; bit 5
D4	26	data output; bit 4
D3	27	data output; bit 3
D2	28	data output; bit 2
D1	29	data output; bit 1
D0	30	data output; bit 0 (Least Significant Bit (LSB))
n.c.	31	not connected
n.c.	32	not connected
$V_{CCO}$	33	output supply voltage (3.3 V)
OGND	34	output ground
CLKN	35	complementary clock input
CLK	36	clock input
$V_{CCD1}$	37	digital supply voltage 1 (5 V)
DGND1	38	digital ground 1
SH	39	sample-and-hold enable input (CMOS level; active HIGH)
AGND4	40	analog ground 4
$V_{CCA4}$	41	analog supply voltage 4 (5 V)
IN	42	analog input voltage
INN	43	complementary analog input voltage
AGND1	44	analog ground 1

## 8. Limiting values

**Table 4.** Limiting values

In accordance with the Absolute Maximum Rating System (IEC 60134).

Symbol	Parameter	Conditions	Min	Max	Unit
$V_{CCA}$	analog supply voltage		[1] -0.3	+7.0	V
$V_{CCD}$	digital supply voltage		[1] -0.3	+7.0	V
$V_{CCO}$	output supply voltage		[1] -0.3	+7.0	V
$\Delta V_{CC}$	supply voltage difference	$V_{CCA} - V_{CCD}$	-1.0	+1.0	V
		$V_{CCD} - V_{CCO}$	-1.0	+4.0	V
		$V_{CCA} - V_{CCO}$	-1.0	+4.0	V
$V_{i(IN)}$	input voltage on pin IN	referenced to AGND	0.3	$V_{CCA}$	V
$V_{i(INN)}$	input voltage on pin INN		0.3	$V_{CCA}$	V

**Table 4. Limiting values ...continued**

In accordance with the Absolute Maximum Rating System (IEC 60134).

Symbol	Parameter	Conditions	Min	Max	Unit
$V_{i(\text{clk})(\text{p-p})}$	peak-to-peak clock input voltage	differential clock drive at pins 35 and 36	-	$V_{\text{CCD}}$	V
$I_{\text{O}}$	output current		-	10	mA
$T_{\text{stg}}$	storage temperature		-55	+150	°C
$T_{\text{amb}}$	ambient temperature		-40	+85	°C
$T_{\text{j}}$	junction temperature		-	150	°C

[1] The supply voltages  $V_{\text{CCA}}$ ,  $V_{\text{CCD}}$  and  $V_{\text{CCO}}$  may have any value between -0.3 V and +7.0 V provided that the supply voltage differences  $\Delta V_{\text{CC}}$  are respected.

## 9. Thermal characteristics

**Table 5. Thermal characteristics**

Symbol	Parameter	Condition	Value	Unit
$R_{\text{th}(j-a)}$	thermal resistance from junction to ambient	in free air	75	K/W

## 10. Characteristics

**Table 6. Characteristics**

$V_{\text{CCA}} = V2$  to  $V44$ ,  $V3$  to  $V4$  and  $V41$  to  $V40 = 4.75$  V to  $5.25$  V;  $V_{\text{CCD}} = V37$  to  $V38$  and  $V15$  to  $V17 = 4.75$  V to  $5.25$  V;  $V_{\text{CCO}} = V33$  to  $V34 = 3.0$  V to  $3.6$  V; AGND and DGND shorted together;  $T_{\text{amb}} = -40$  °C to  $+85$  °C;

$V_{I(\text{IN})(\text{p-p})} - V_{I(\text{INN})(\text{p-p})} = 1.9$  V;  $V_{\text{VREF}} = V_{\text{CCA}3} - 1.75$  V;  $V_{I(\text{cm})} = V_{\text{CCA}3} - 1.6$  V; typical values measured at  $V_{\text{CCA}} = V_{\text{CCD}} = 5$  V and  $V_{\text{CCO}} = 3.3$  V,  $T_{\text{amb}} = 25$  °C and  $C_{\text{L}} = 10$  pF; unless otherwise specified.

Symbol	Parameter	Conditions	Test <sup>[1]</sup>	Min	Typ	Max	Unit
<b>Supplies</b>							
$V_{\text{CCA}}$	analog supply voltage			4.75	5.0	5.25	V
$V_{\text{CCD}}$	digital supply voltage			4.75	5.0	5.25	V
$V_{\text{CCO}}$	output supply voltage			3.0	3.3	3.6	V
$I_{\text{CCA}}$	analog supply current		I	-	78	87	mA
$I_{\text{CCD}}$	digital supply current		I	-	27	30	mA
$I_{\text{CCO}}$	output supply current	$f_{\text{clk}} = 20$ MHz; $f_i = 400$ kHz	I	-	3	4	mA
		$f_{\text{clk}} = 55$ MHz; $f_i = 20$ MHz	I	-	9.5	12	mA
$P_{\text{tot}}$	total power dissipation	$f_{\text{clk}} = 55$ MHz; $f_i = 20$ MHz		-	550	660	mW
<b>Inputs</b>							
CLK and CLKN (referenced to DGND) <sup>[2]</sup>							
$V_{\text{IL}}$	LOW-level input voltage	PECL mode; $V_{\text{CCD}} = 5$ V	I	3.19	-	3.52	V
		TTL mode	C	0	-	0.8	V

**Table 6. Characteristics ...continued**

$V_{CCA} = V2$  to  $V44$ ,  $V3$  to  $V4$  and  $V41$  to  $V40 = 4.75$  V to  $5.25$  V;  $V_{CCD} = V37$  to  $V38$  and  $V15$  to  $V17 = 4.75$  V to  $5.25$  V;  $V_{CCO} = V33$  to  $V34 = 3.0$  V to  $3.6$  V; AGND and DGND shorted together;  $T_{amb} = -40$  °C to  $+85$  °C;  $V_{I(IN)(p-p)} - V_{I(INN)(p-p)} = 1.9$  V;  $V_{VREF} = V_{CCA3} - 1.75$  V;  $V_{I(cm)} = V_{CCA3} - 1.6$  V; typical values measured at  $V_{CCA} = V_{CCD} = 5$  V and  $V_{CCO} = 3.3$  V,  $T_{amb} = 25$  °C and  $C_L = 10$  pF; unless otherwise specified.

Symbol	Parameter	Conditions	Test <sup>[1]</sup>	Min	Typ	Max	Unit
$V_{IH}$	HIGH-level input voltage	PECL mode; $V_{CCD} = 5$ V	I	3.83	-	4.12	V
		TTL mode	C	2.0	-	$V_{CCD}$	V
$I_{IL}$	LOW-level input current	$V_{CLK}$ or $V_{CLKN} = 3.19$ V	C	-10	-	-	μA
$I_{IH}$	HIGH-level input current	$V_{CLK}$ or $V_{CLKN} = 3.83$ V	C	-	-	10	μA
$V_{i(dif)(p-p)}$	peak-to-peak differential input voltage	AC driving mode; DC voltage level = 2.5 V	C	1	1.5	2.0	V
$R_i$	input resistance	$f_{clk} = 55$ MHz	D	2	-	-	kΩ
$C_i$	input capacitance	$f_{clk} = 55$ MHz	D	-	-	2	pF

OTC, SH and  $\overline{CE}$  (referenced to DGND); see [Table 7](#) and [8](#)

$V_{IL}$	LOW-level input voltage		I	0	-	0.8	V
$V_{IH}$	HIGH-level input voltage		I	2.0	-	$V_{CCD}$	V
$I_{IL}$	LOW-level input current	$V_{IL} = 0.8$ V	I	-20	-	-	μA
$I_{IH}$	HIGH-level input current	$V_{IH} = 2.0$ V	I	-	-	20	μA

IN and INN (referenced to AGND); see [Table 7](#),  $V_{VREF} = V_{CCA3} - 1.75$  V

$I_{IL}$	LOW-level input current	SH = HIGH	C	-	10	-	μA
$I_{IH}$	HIGH-level input current	SH = HIGH	C	-	10	-	μA
$R_i$	input resistance	$f_i = 20$ MHz	D	-	14	-	MΩ
$C_i$	input capacitance	$f_i = 20$ MHz	D	-	450	-	fF
$V_{I(cm)}$	common-mode input voltage	$V_{I(IN)} = V_{I(INN)}$ output code 512	C	$V_{CCA3} - 1.7$	$V_{CCA3} - 1.6$	$V_{CCA3} - 1.2$	V

**Voltage controlled regulator output CMADC**

$V_{O(cm)}$	common-mode output voltage		I	-	$V_{CCA3} - 1.6$	-	V
$I_{load}$	load current		I	-	1	2	mA

**Voltage input  $V_{ref}$ <sup>[3]</sup>**

$V_{ref}$	reference voltage	full-scale fixed voltage; $f_i = 20$ MHz; $f_{clk} = 55$ MHz	C	-	$V_{CCA3} - 1.75$	-	V
$I_{ref}$	reference current		C	-	0.3	10	μA
$V_{i(dif)(p-p)}$	peak-to-peak differential input voltage	$V_{I(IN)(p-p)} - V_{I(INN)(p-p)}$ ; $V_{ref} = V_{CCA3} - 1.75$ V; $V_{I(cm)} = V_{CCA3} - 1.6$ V	C	-	1.9	-	V

**Table 6. Characteristics ...continued**

$V_{CCA} = V2$  to  $V44$ ,  $V3$  to  $V4$  and  $V41$  to  $V40 = 4.75$  V to  $5.25$  V;  $V_{CCD} = V37$  to  $V38$  and  $V15$  to  $V17 = 4.75$  V to  $5.25$  V;  $V_{CCO} = V33$  to  $V34 = 3.0$  V to  $3.6$  V; AGND and DGND shorted together;  $T_{amb} = -40$  °C to  $+85$  °C;  $V_{I(IN)(p-p)} - V_{I(INN)(p-p)} = 1.9$  V;  $V_{VREF} = V_{CCA3} - 1.75$  V;  $V_{I(cm)} = V_{CCA3} - 1.6$  V; typical values measured at  $V_{CCA} = V_{CCD} = 5$  V and  $V_{CCO} = 3.3$  V,  $T_{amb} = 25$  °C and  $C_L = 10$  pF; unless otherwise specified.

Symbol	Parameter	Conditions	Test <sup>[1]</sup>	Min	Typ	Max	Unit
<b>Voltage controlled regulator output FSREF</b>							
$V_{O(ref)}$	reference output voltage	$V_{I(IN)(p-p)} - V_{I(INN)(p-p)} = 1.9$ V	I	-	$V_{CCA3} - 1.75$	-	V
<b>Digital outputs D9 to D0 and IR (referenced to OGND)</b>							
$V_{OL}$	LOW-level output voltage	$I_{OL} = 2$ mA	I	0	-	0.5	V
$V_{OH}$	HIGH-level output voltage	$I_{OH} = -0.4$ mA	I	$V_{CCO} - 0.5$	-	$V_{CCO}$	V
$I_o$	output current	3-state output level between 0.5 V and $V_{CCO}$	I	-20	-	+20	µA
<b>Switching characteristics; Clock frequency <math>f_{clk}</math>; see Figure 3</b>							
$f_{clk(min)}$	minimum clock frequency	SH = HIGH	C	-	-	7	MHz
$f_{clk(max)}$	maximum clock frequency	ADC1006S055H	I	55	-	-	MHz
		ADC1006S070H	C	70	-	-	MHz
$t_{w(ck)H}$	HIGH clock pulse width	$f_i = 20$ MHz	C	6.8	-	-	ns
$t_{w(ck)L}$	LOW clock pulse width	$f_i = 20$ MHz	C	6.8	-	-	ns
<b>Analog signal processing; 50 % clock duty factor; <math>V_{I(IN)(p-p)} - V_{I(INN)(p-p)} = 1.9</math> V; <math>V_{VREF} = V_{CCA3} - 1.75</math> V; see Table 7</b>							
<b>Linearity</b>							
INL	integral non-linearity	$f_{clk} = 20$ MHz; $f_i = 400$ kHz	I	-	±0.65	±1.12	LSB
DNL	differential non-linearity	$f_{clk} = 20$ MHz; $f_i = 400$ kHz (no missing code guaranteed)	I	-	±0.12	±0.27	LSB
$E_{offset}$	offset error	$V_{CCA} = V_{CCD} = 5$ V; $V_{CCO} = 3.3$ V; $T_{amb} = 25$ °C; output code = 512	C	-25	+5	+25	mV
$E_G$	gain error	spread from device to device; $V_{CCA} = V_{CCD} = 5$ V; $V_{CCO} = 3.3$ V; $T_{amb} = 25$ °C	C	-7	-	+7	%FS
<b>Bandwidth (<math>f_{clk} = 55</math> MHz)<sup>[4]</sup></b>							
B	bandwidth	-3 dB; full-scale input	C	220	245	-	MHz



**Table 6. Characteristics ...continued**

$V_{CCA} = V2$  to  $V44$ ,  $V3$  to  $V4$  and  $V41$  to  $V40 = 4.75$  V to  $5.25$  V;  $V_{CCD} = V37$  to  $V38$  and  $V15$  to  $V17 = 4.75$  V to  $5.25$  V;  $V_{CCO} = V33$  to  $V34 = 3.0$  V to  $3.6$  V; AGND and DGND shorted together;  $T_{amb} = -40$  °C to  $+85$  °C;  $V_{I(IN)(p-p)} - V_{I(INN)(p-p)} = 1.9$  V;  $V_{VREF} = V_{CCA3} - 1.75$  V;  $V_{I(cm)} = V_{CCA3} - 1.6$  V; typical values measured at  $V_{CCA} = V_{CCD} = 5$  V and  $V_{CCO} = 3.3$  V,  $T_{amb} = 25$  °C and  $C_L = 10$  pF; unless otherwise specified.

Symbol	Parameter	Conditions	Test <sup>[1]</sup>	Min	Typ	Max	Unit
<b>Harmonics</b>							
$\alpha_{2H}$	second harmonic level	ADC1006S055H ( $f_{clk} = 55$ MHz)					
		$f_i = 4.43$ MHz	C	-	-77	-	dBFS
		$f_i = 10$ MHz	C	-	-76	-	dBFS
		$f_i = 15$ MHz	C	-	-75	-	dBFS
		$f_i = 20$ MHz	I	-	-73	-	dBFS
		ADC1006S070H ( $f_{clk} = 70$ MHz)					
		$f_i = 4.43$ MHz	C	-	-75	-	dBFS
		$f_i = 10$ MHz	C	-	-74	-	dBFS
		$f_i = 15$ MHz	C	-	-70	-	dBFS
		$\alpha_{3H}$	third harmonic level	ADC1006S055H ( $f_{clk} = 55$ MHz)			
$f_i = 4.43$ MHz	C			-	-73	-	dBFS
$f_i = 10$ MHz	C			-	-73	-	dBFS
$f_i = 15$ MHz	C			-	-73	-	dBFS
$f_i = 20$ MHz	I			-	-72	-	dBFS
ADC1006S070H ( $f_{clk} = 70$ MHz)							
$f_i = 4.43$ MHz	C			-	-73	-	dBFS
$f_i = 10$ MHz	C			-	-73	-	dBFS
$f_i = 15$ MHz	C			-	-72	-	dBFS
<b>Total harmonic distortion<sup>[5]</sup></b>							
THD	total harmonic distortion	ADC1006S055H ( $f_{clk} = 55$ MHz)					
		$f_i = 4.43$ MHz	C	-	-68	-	dBFS
		$f_i = 10$ MHz	C	-	-68	-	dBFS
		$f_i = 15$ MHz	C	-	-68	-	dBFS
		$f_i = 20$ MHz	I	-	-68	-	dBFS
		ADC1006S070H ( $f_{clk} = 70$ MHz)					
		$f_i = 4.43$ MHz	C	-	-67	-	dBFS
		$f_i = 10$ MHz	C	-	-67	-	dBFS
		$f_i = 15$ MHz	C	-	-66	-	dBFS
		<b>Thermal noise</b>					
$N_{th(RMS)}$	RMS thermal noise	shorted input; SH = HIGH; $f_{clk} = 55$ MHz	C	-	0.12	-	LSB

**Table 6. Characteristics ...continued**

$V_{CCA} = V2$  to  $V44$ ,  $V3$  to  $V4$  and  $V41$  to  $V40 = 4.75$  V to  $5.25$  V;  $V_{CCD} = V37$  to  $V38$  and  $V15$  to  $V17 = 4.75$  V to  $5.25$  V;  $V_{CCO} = V33$  to  $V34 = 3.0$  V to  $3.6$  V; AGND and DGND shorted together;  $T_{amb} = -40$  °C to  $+85$  °C;  $V_{I(IN)(p-p)} - V_{I(INN)(p-p)} = 1.9$  V;  $V_{VREF} = V_{CCA3} - 1.75$  V;  $V_{I(cm)} = V_{CCA3} - 1.6$  V; typical values measured at  $V_{CCA} = V_{CCD} = 5$  V and  $V_{CCO} = 3.3$  V,  $T_{amb} = 25$  °C and  $C_L = 10$  pF; unless otherwise specified.

Symbol	Parameter	Conditions	Test <sup>[1]</sup>	Min	Typ	Max	Unit
<b>Signal-to-noise ratio<sup>[6]</sup></b>							
S/N	signal-to-noise ratio	ADC1006S055H ( $f_{clk} = 55$ MHz)					
		$f_i = 4.43$ MHz	C	-	60	-	dBFS
		$f_i = 10$ MHz	C	-	60	-	dBFS
		$f_i = 15$ MHz	C	-	60	-	dBFS
		$f_i = 20$ MHz	I	-	59.5	-	dBFS
		ADC1006S070H ( $f_{clk} = 70$ MHz)					
		$f_i = 4.43$ MHz	C	-	60	-	dBFS
		$f_i = 10$ MHz	C	-	60	-	dBFS
		$f_i = 15$ MHz	C	-	59	-	dBFS
<b>Spurious free dynamic range; see Figure 7, 13 and 14</b>							
SFDR	spurious free dynamic range	ADC1006S055H ( $f_{clk} = 55$ MHz)					
		$f_i = 4.43$ MHz	C	-	71	-	dBFS
		$f_i = 10$ MHz	C	-	70	-	dBFS
		$f_i = 15$ MHz	C	-	70	-	dBFS
		$f_i = 20$ MHz	I	-	70	-	dBFS
		ADC1006S070H ( $f_{clk} = 70$ MHz)					
		$f_i = 4.43$ MHz	C	-	70	-	dBFS
		$f_i = 10$ MHz	C	-	69	-	dBFS
		$f_i = 15$ MHz	C	-	68	-	dBFS
<b>Effective number of bits<sup>[7]</sup></b>							
ENOB	effective number of bits	ADC1006S055H ( $f_{clk} = 55$ MHz)					
		$f_i = 4.43$ MHz	C	-	9.5	-	bit
		$f_i = 10$ MHz	C	-	9.5	-	bit
		$f_i = 15$ MHz	C	-	9.5	-	bit
		$f_i = 20$ MHz	I	-	9.5	-	bit
		ADC1006S070H ( $f_{clk} = 70$ MHz)					
		$f_i = 4.43$ MHz	C	-	9.5	-	bit
		$f_i = 10$ MHz	C	-	9.5	-	bit
		$f_i = 15$ MHz	C	-	9.4	-	bit
<b>Intermodulation; (<math>f_{clk} = 55</math> MHz; <math>f_i = 20</math> MHz)<sup>[8]</sup></b>							
$\alpha_{IM}$	intermodulation suppression		C	-	-69	-	dBFS
IMD3	third-order intermodulation distortion		C	-	-79	-	dBFS
<b>Bit error rate (<math>f_{clk} = 55</math> MHz)</b>							
BER	bit error rate	$f_i = 20$ MHz; $V_I = \pm 16$ LSB at code 512	C	-	$10^{-14}$	-	times/sample

**Table 6. Characteristics ...continued**

$V_{CCA} = V2$  to  $V44$ ,  $V3$  to  $V4$  and  $V41$  to  $V40 = 4.75$  V to  $5.25$  V;  $V_{CCD} = V37$  to  $V38$  and  $V15$  to  $V17 = 4.75$  V to  $5.25$  V;  $V_{CCO} = V33$  to  $V34 = 3.0$  V to  $3.6$  V; AGND and DGND shorted together;  $T_{amb} = -40$  °C to  $+85$  °C;  $V_{I(IN)(p-p)} - V_{I(INN)(p-p)} = 1.9$  V;  $V_{VREF} = V_{CCA3} - 1.75$  V;  $V_{I(cm)} = V_{CCA3} - 1.6$  V; typical values measured at  $V_{CCA} = V_{CCD} = 5$  V and  $V_{CCO} = 3.3$  V,  $T_{amb} = 25$  °C and  $C_L = 10$  pF; unless otherwise specified.

Symbol	Parameter	Conditions	Test <sup>[1]</sup>	Min	Typ	Max	Unit
<b>Timing (<math>C_L = 10</math> pF)<sup>[9]</sup></b>							
$t_{d(s)}$	sampling delay time		C	-	0.25	1	ns
$t_{h(o)}$	output hold time		C	4	6.4	-	ns
$t_{d(o)}$	output delay time		C	-	9.0	13	ns
<b>3-state output delay times; see Figure 4</b>							
$t_{dZH}$	float to active HIGH delay time		C	-	5.1	9.0	ns
$t_{dZL}$	float to active LOW delay time		C	-	7.0	11	ns
$t_{dHZ}$	active HIGH to float delay time		C	-	9.7	14	ns
$t_{dLZ}$	active LOW to float delay time		C	-	9.5	13	ns

- [1] D = guaranteed by design; C = guaranteed by characterization; I = 100 % industrially tested.
- [2] The circuit has two clock inputs: CLK and CLKN. There are 5 modes of operation:
  - a) PECL mode 1: (DC level vary 1 : 1 with  $V_{CCD}$ ) CLK and CLKN inputs are at differential PECL levels.
  - b) PECL mode 2: (DC level vary 1 : 1 with  $V_{CCD}$ ) CLK input is at PECL level and sampling is taken on the falling edge of the clock input signal. A DC level of 3.65 V has to be applied on CLKN decoupled to GND via a 100 nF capacitor.
  - c) PECL mode 3: (DC level vary 1 : 1 with  $V_{CCD}$ ) CLKN input is at PECL level and sampling is taken on the rising edge of the clock input signal. A DC level of 3.65 V has to be applied on CLK decoupled to GND via a 100 nF capacitor.
  - d) Differential AC driving mode 4: When driving the CLK input directly and with any AC signal of minimum 1 V (p-p) and with a DC level of 2.5 V, the sampling takes place at the falling edge of the clock signal. When driving the CLKN input with the same signal, sampling takes place at the rising edge of the clock signal. It is recommended to decouple the CLKN or CLK input to DGND via a 100 nF capacitor.
  - e) TTL mode 1: CLK input is at TTL level and sampling is taken on the falling edge of the clock input signal. In that case CLKN pin has to be connected to the ground.
- [3] The ADC input range can be adjusted with an external reference connected to VREF pin. This voltage has to be referenced to  $V_{CCA}$ ; see Figure 12.
- [4] The -3 dB analog bandwidth is determined by the 3 dB reduction in the reconstructed output, the input being a full-scale sine wave.
- [5] Total Harmonic Distortion (THD) is obtained with the addition of the first five harmonics:

$$THD = 20 \log \frac{\sqrt{(\alpha_{2H})^2 + (\alpha_{3H})^2 + (\alpha_{4H})^2 + (\alpha_5)^2 + (\alpha_{6H})^2}}{(a_{1H})^2}$$

where  $\alpha_{1H}$  is the fundamental harmonic referenced at 0 dB for a full-scale sine wave input; see Figure 6.

- [6] Signal-to-noise ratio (S/N) takes into account all harmonics above five and noise up to Nyquist frequency; see Figure 8.
- [7] Effective number of bits are obtained via a Fast Fourier Transform (FFT). The calculation takes into account all harmonics and noise up to half of the clock frequency (Nyquist frequency). Conversion to Signal-to\_Noise\_Distortion ratio (SINAD) is given by  $SINAD = ENOB \times 6.02 + 1.76$  dB; see Figure 5.
- [8] Intermodulation measured relative to either tone with analog input frequencies of 20 MHz and 20.1 MHz. The two input signals have the same amplitude and the total amplitude of both signals provides full-scale to the converter (-6 dB below full scale for each input signal). IMD3 is the ratio of the RMS value of either input tone to the RMS value of the worst case third order intermodulation product.
- [9] Output data acquisition: the output data is available after the maximum delay of  $t_{d(o)}$ ; see Figure 3.

11. Additional information relating to [Table 6](#)

**Table 7. Output coding with differential inputs (typical values to AGND);**  
 $V_{i(IN)(p-p)} - V_{i(INN)(p-p)} = 1.9\text{ V}$ ,  $V_{VREF} = V_{CCA3} - 1.75\text{ V}$

Code	$V_{i(a)(p-p)}$ (V)	$V_{i(a)(p-p)}$ (V)	IR	Binary outputs D9 to D0	Two's complement outputs <sup>[1]</sup> D9 to D0
Underflow	< 3.125	> 4.075	0	00 0000 0000	10 0000 0000
0	3.125	4.075	1	00 0000 0000	10 0000 0000
1	-	-	1	00 0000 0001	10 0000 0001
↓	-	-	↓	↓	↓
511	3.6	3.6	1	01 1111 1111	11 1111 1111
↓	-	-	↓	↓	↓
1022	-	-	1	11 1111 1110	01 1111 1110
1023	4.075	3.125	1	11 1111 1111	01 1111 1111
Overflow	> 4.075	< 3.125	0	11 1111 1111	01 1111 1111

[1] Two's complement reference is inverted MSB.

**Table 8. Mode selection**

OTC	$\overline{CE}$	D0 to D9 and IR
0	0	binary; active
1	0	two's complement; active
X <sup>[1]</sup>	1	high-impedance

[1] X = don't care.

**Table 9. Sample-and-hold selection**

SH	Sample-and-hold
1	active
0	inactive; tracking mode

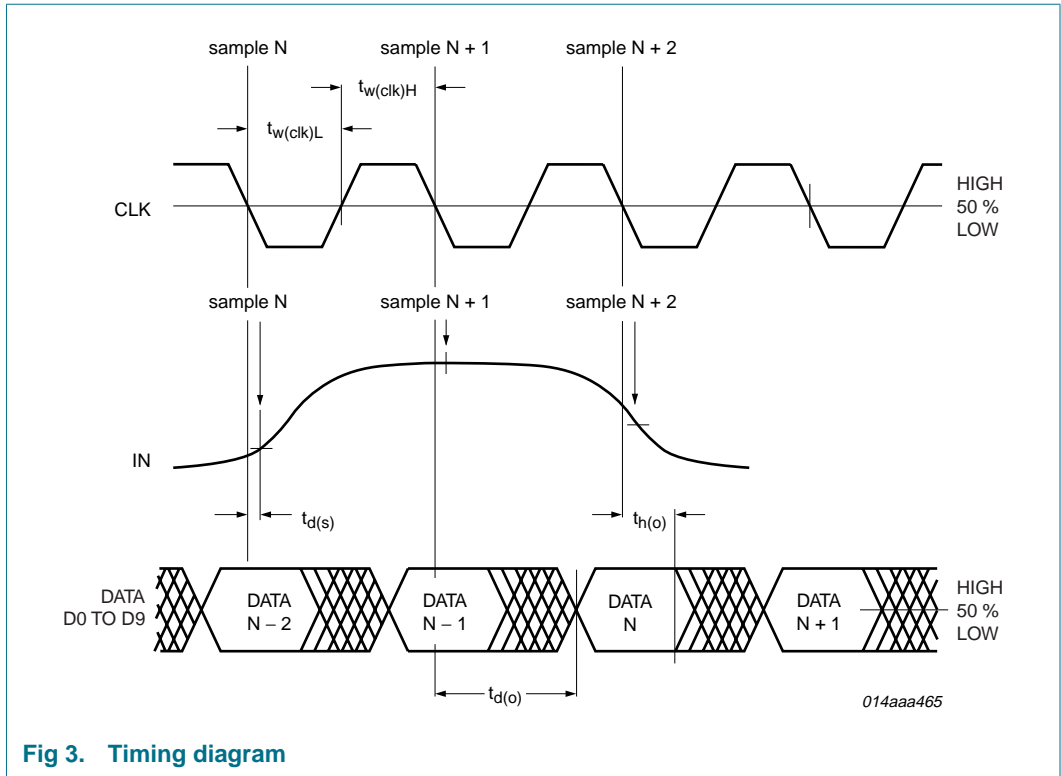


Fig 3. Timing diagram

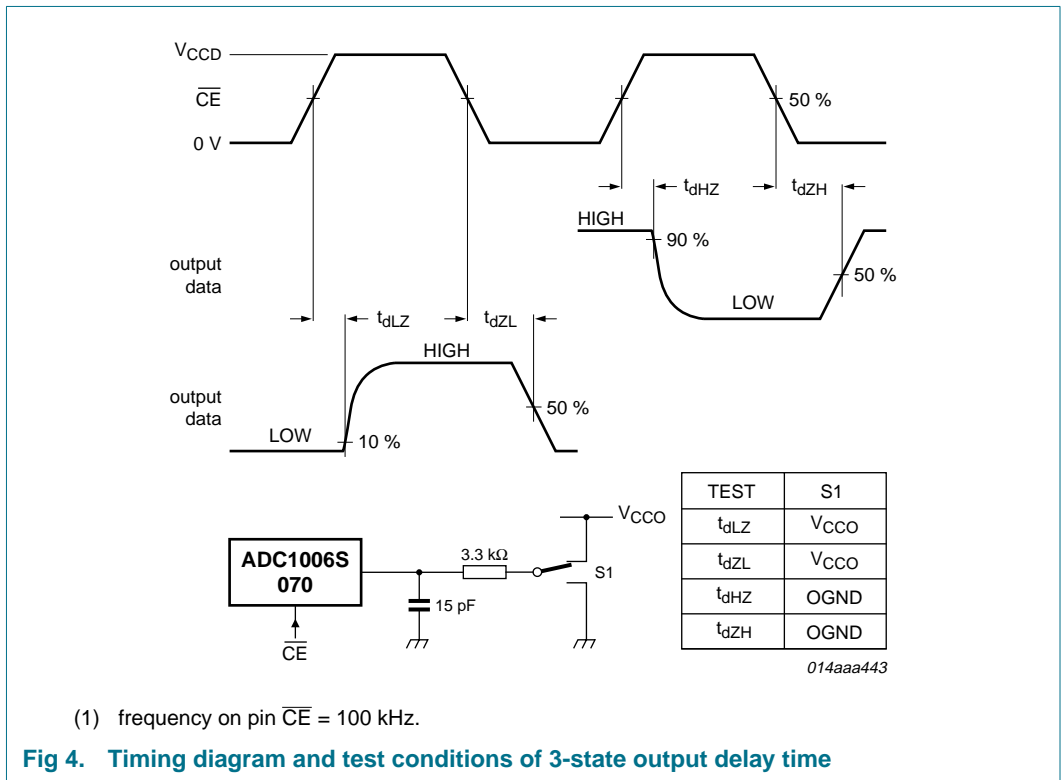
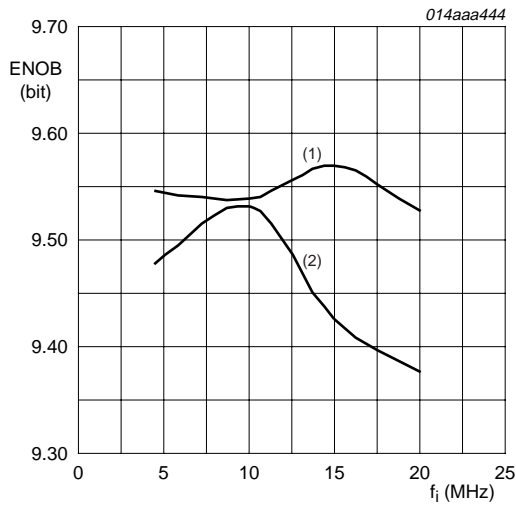
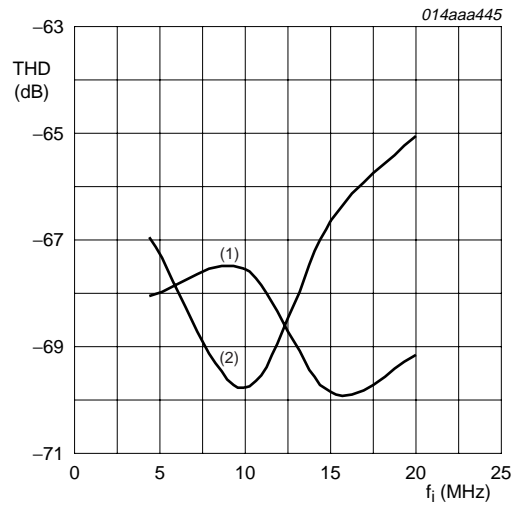


Fig 4. Timing diagram and test conditions of 3-state output delay time



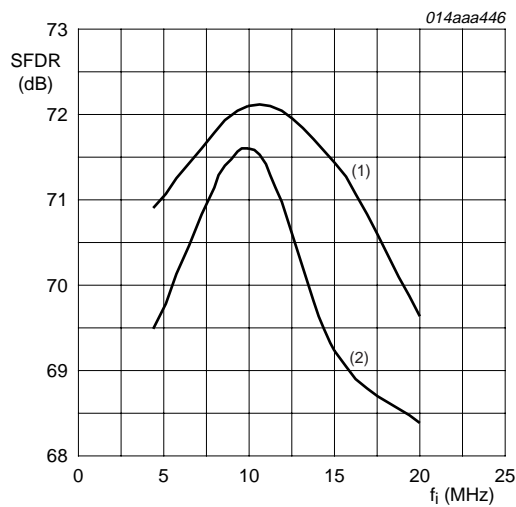
- (1) 55 MHz.
- (2) 70 MHz.

Fig 5. Effective Number Of Bits (ENOB) as a function of input frequency (sample device)



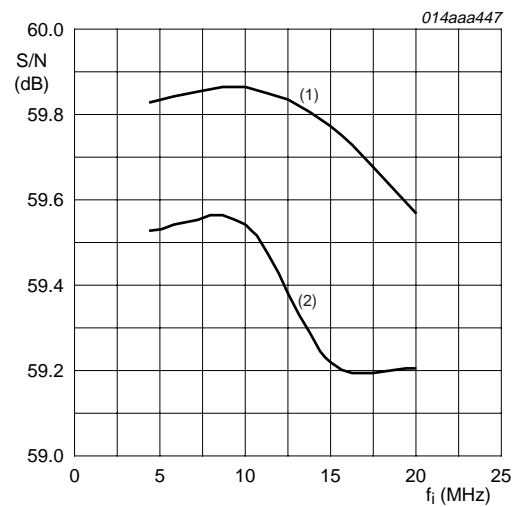
- (1) 55 MHz.
- (2) 70 MHz.

Fig 6. Total Harmonic Distortion (THD) as a function of input frequency (sample device)



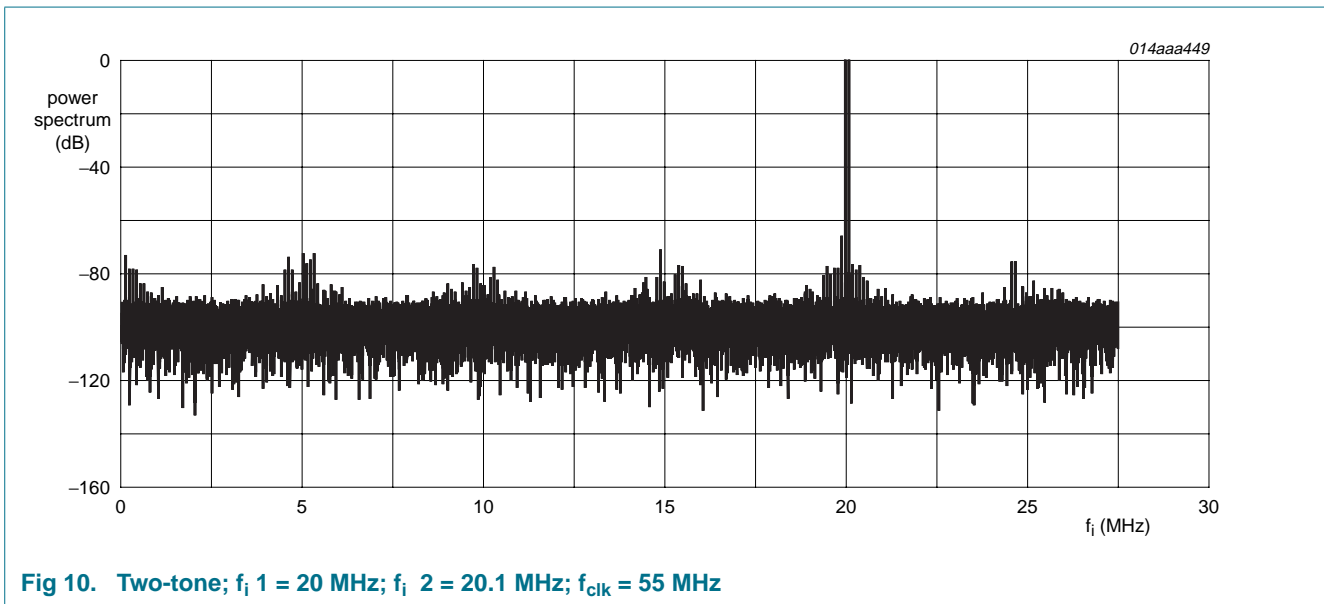
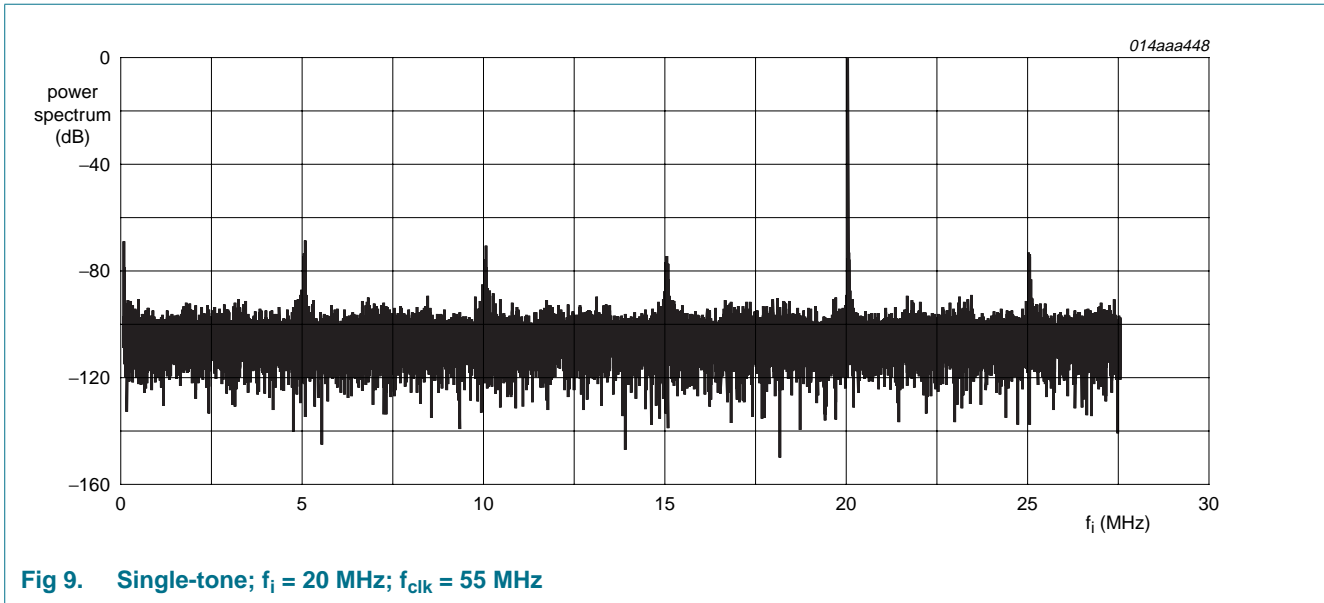
- (1) 55 MHz.
- (2) 70 MHz.

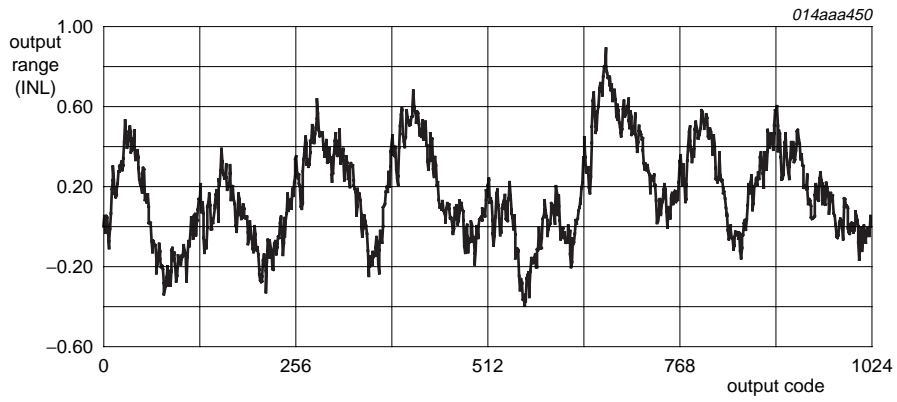
Fig 7. Spurious Free Dynamic Range (SFDR) as a function of input frequency (sample device)



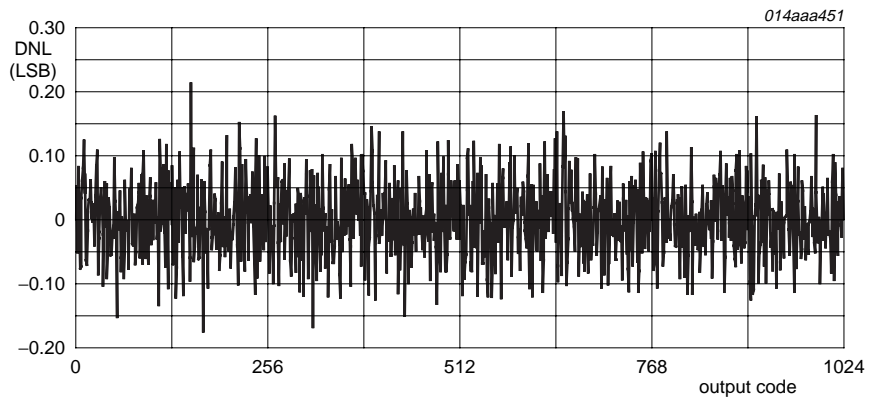
- (1) 55 MHz.
- (2) 70 MHz.

Fig 8. Signal-to-Noise Ratio (S/N) as a function of input frequency (sample device)



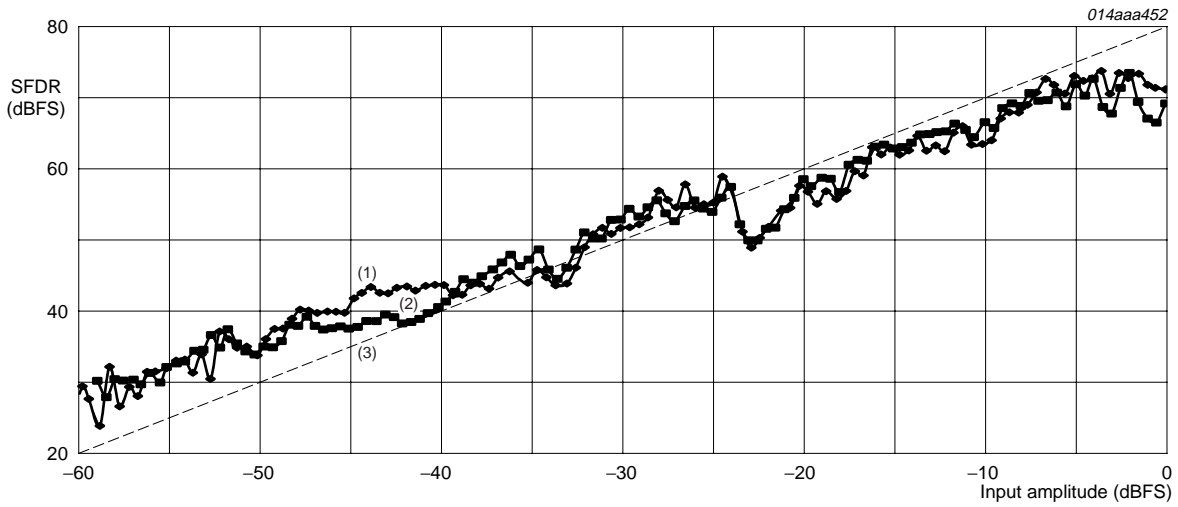


**Fig 11. Integral Non-Linearity (INL)**



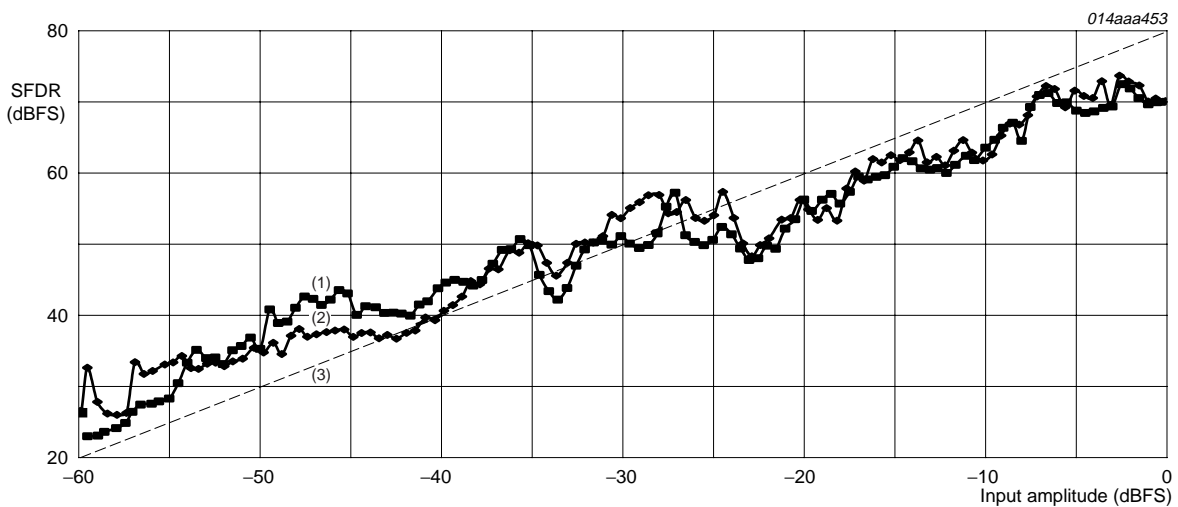
**Fig 12. Differential Non-Linearity (DNL)**





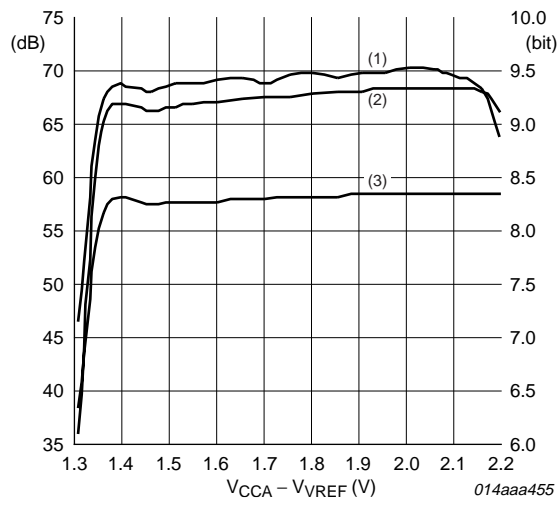
- (1)  $f_i = 4.43$  MHz.
- (2)  $f_i = 20$  MHz.
- (3) SFDR = 80 dB.

Fig 13. SFDR as a function of input amplitude;  $V_{i(IN)(p-p)} - V_{i(INN)(p-p)} = 1.9$  V;  $f_{clk} = 40$  MHz



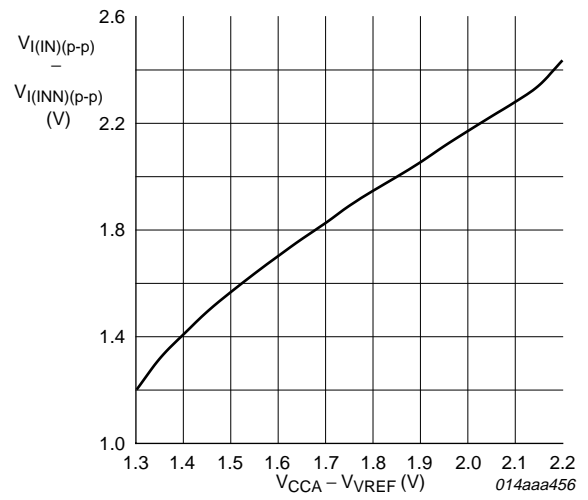
- (1)  $f_i = 4.43$  MHz.
- (2)  $f_i = 20$  MHz.
- (3) SFDR = 80 dB.

Fig 14. SFDR as a function of input amplitude;  $V_{i(IN)(p-p)} - V_{i(INN)(p-p)} = 1.9$  V;  $f_{clk} = 55$  MHz



- (1) SFDR.
- (2) ENOB.
- (3) S/N.

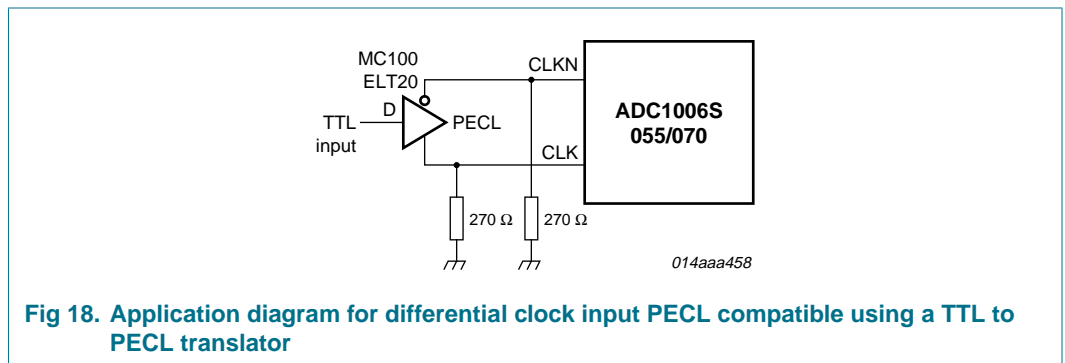
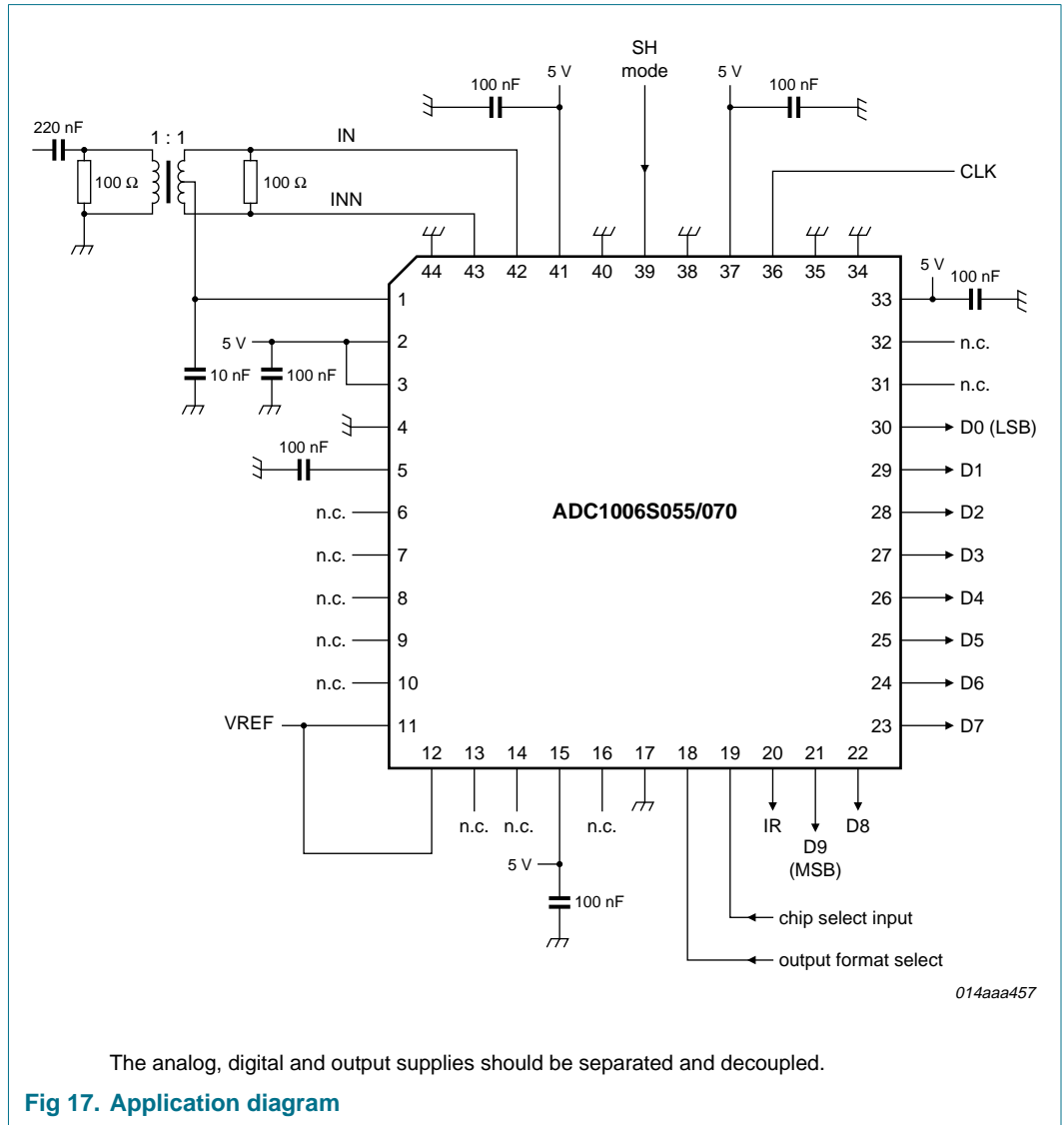
**Fig 15. SFDR, ENOB and S/N as a function of  $V_{CCA} - V_{VREF}$ ;  $f_{clk} = 55$  MHz;  $f_i = 20$  MHz**



**Fig 16. ADC full-scale;  $V_{I(IN)(p-p)} - V_{I(INN)(p-p)}$  as a function of  $V_{CCA} - V_{VREF}$**

12. Application information

12.1 Application diagrams



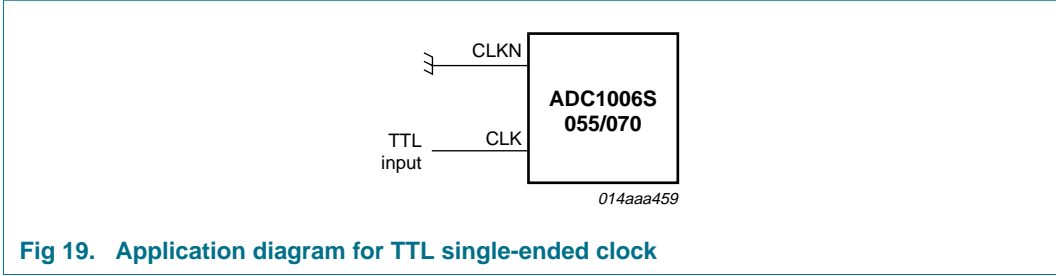
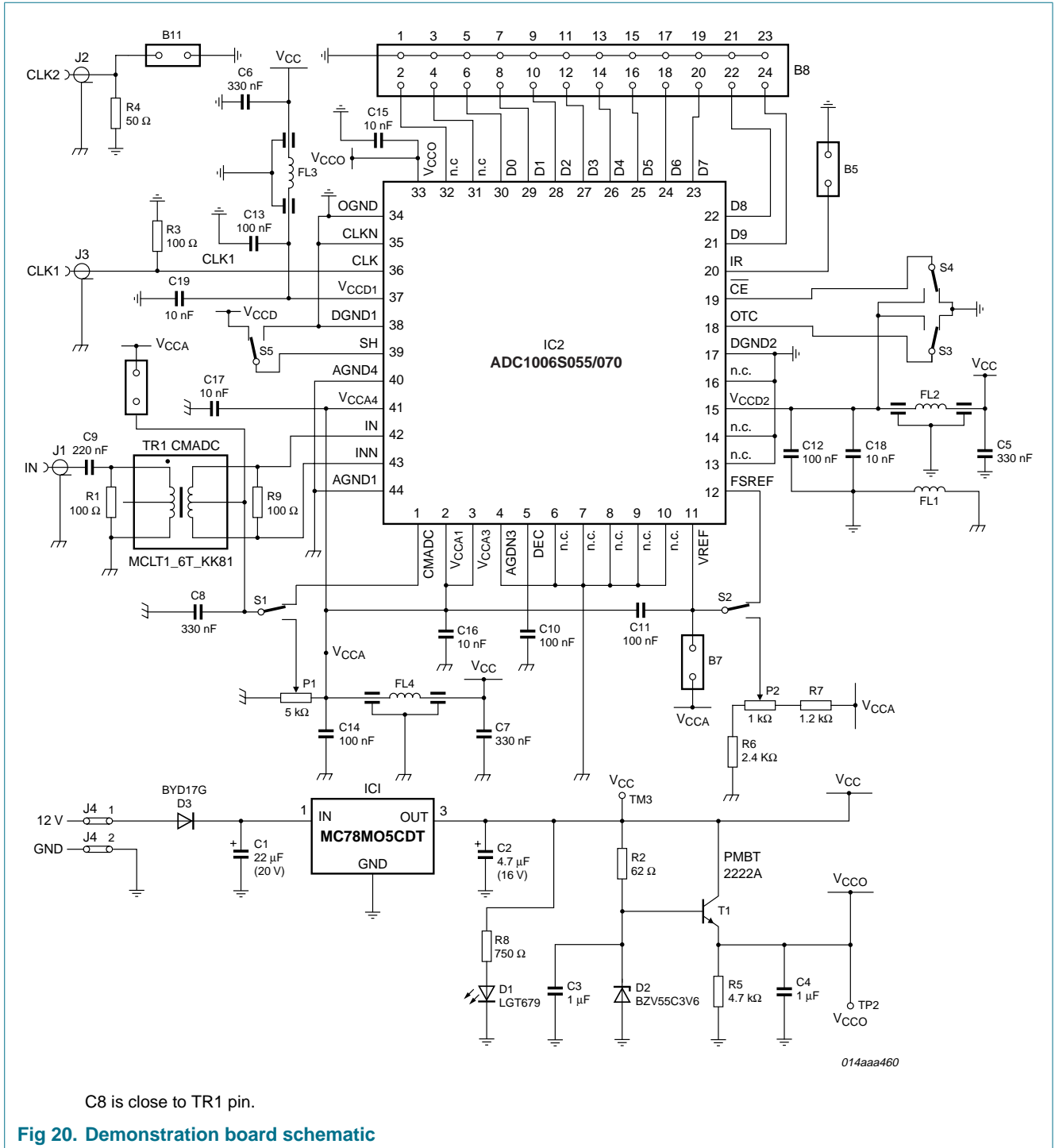


Fig 19. Application diagram for TTL single-ended clock

## 12.2 Demonstration board



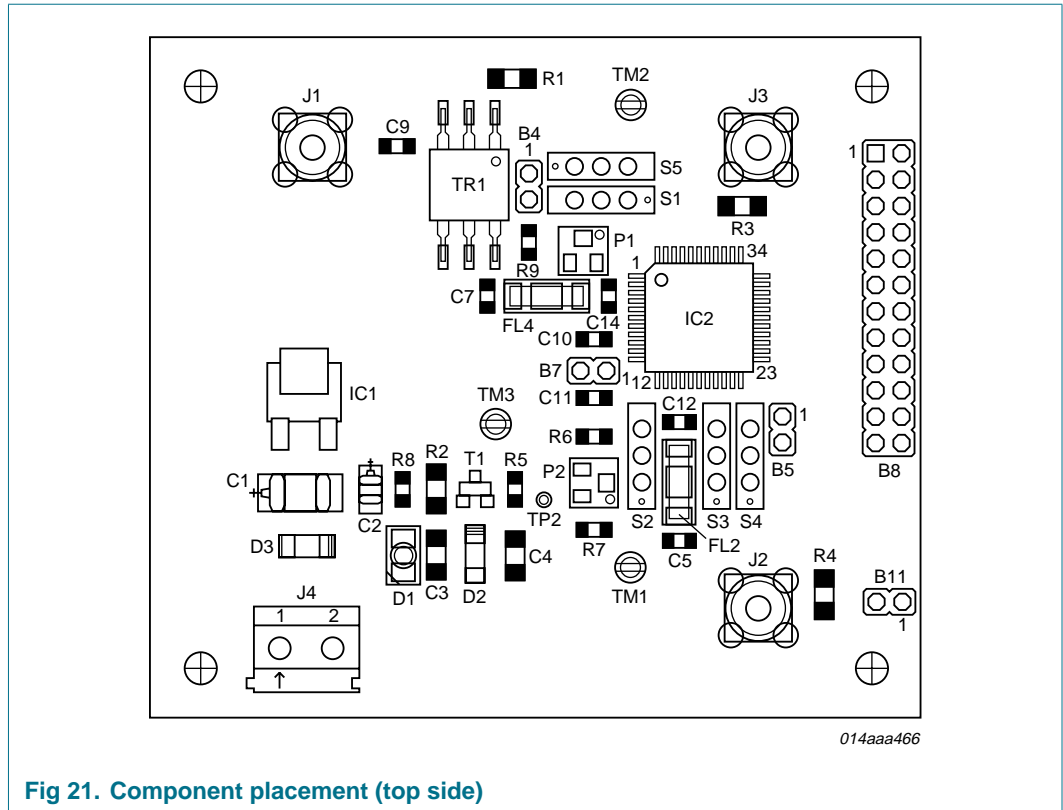


Fig 21. Component placement (top side)

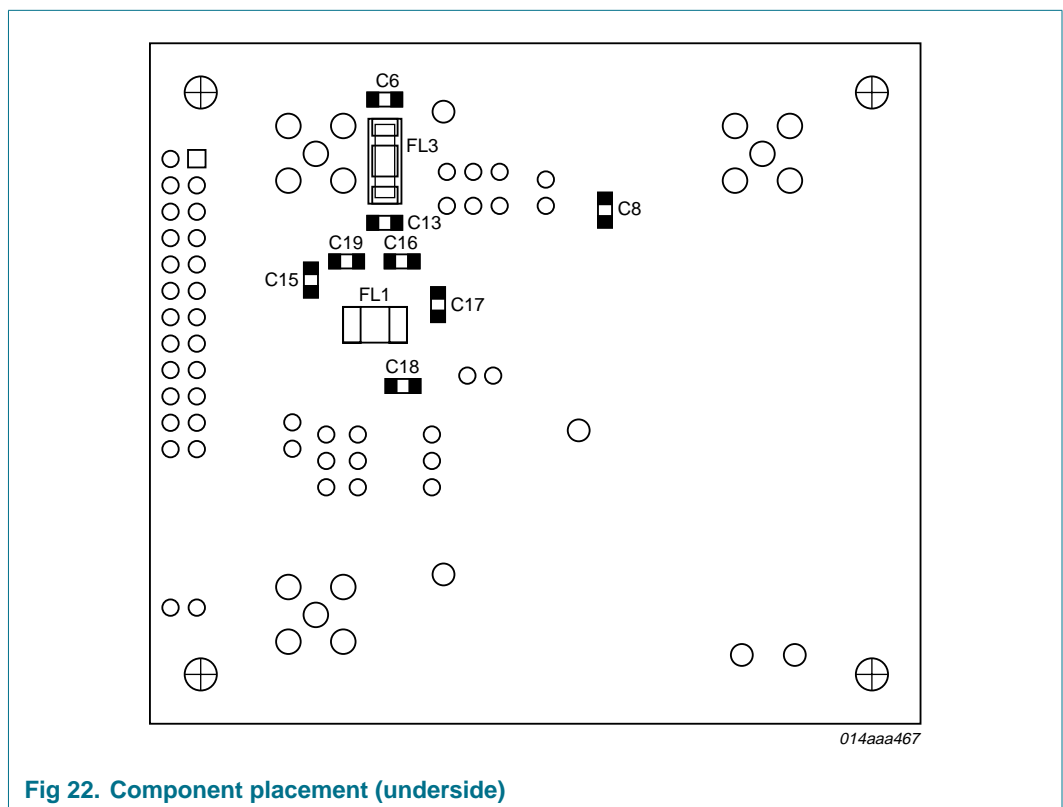
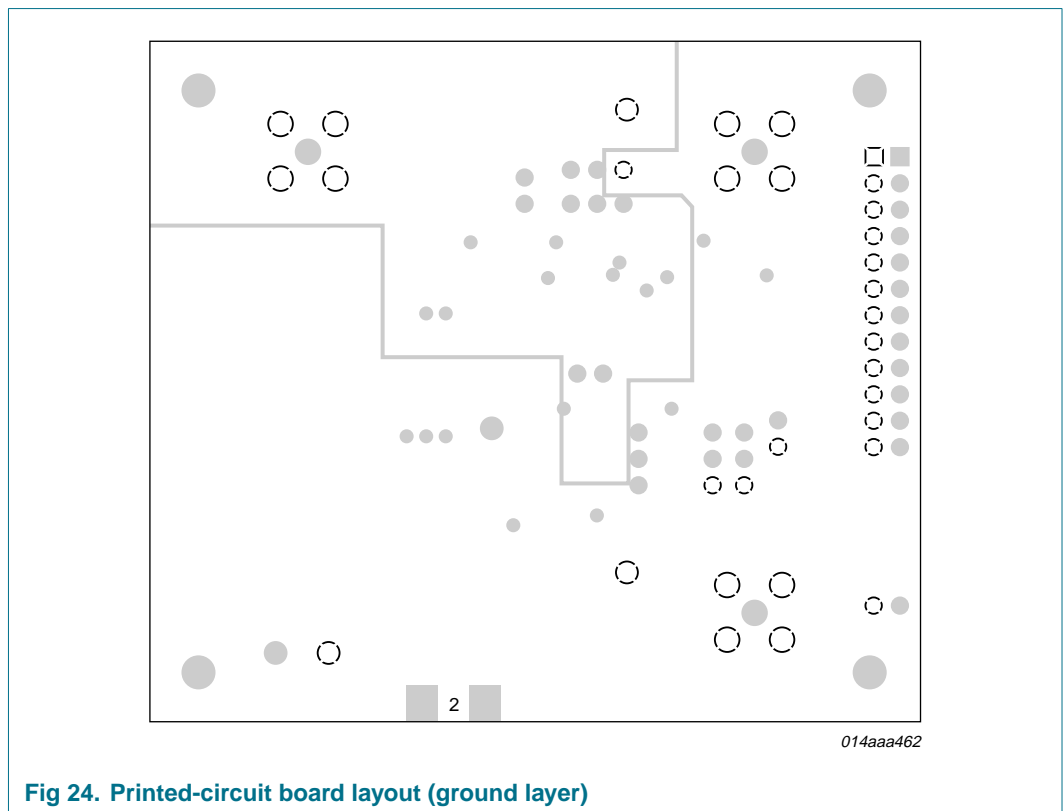
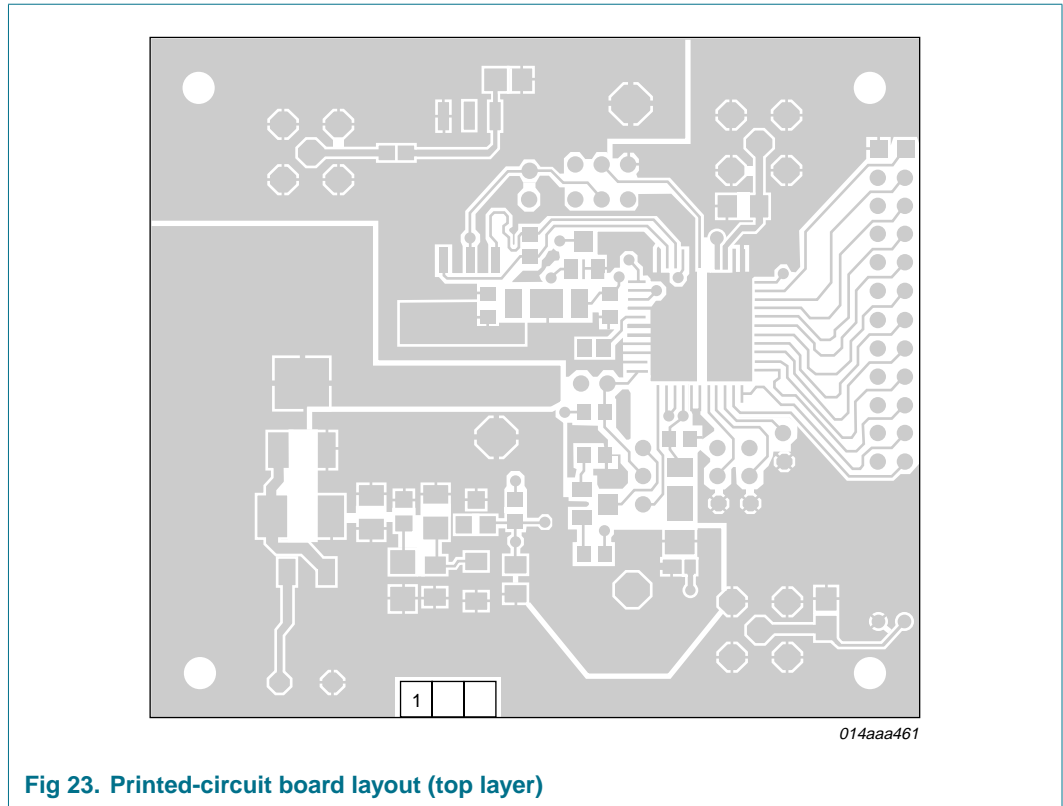
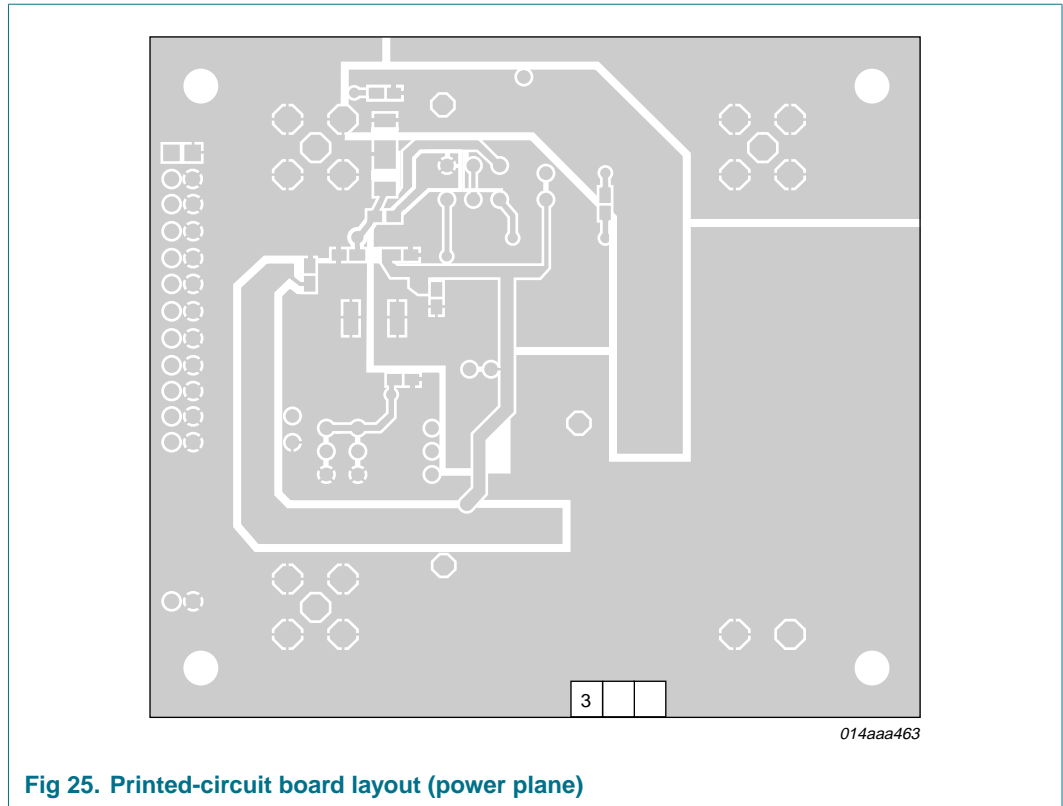


Fig 22. Component placement (underside)





**Fig 25. Printed-circuit board layout (power plane)**

### 12.3 Alternative parts

The following alternative parts are also available:

**Table 10. Alternative parts**

Type number	Description		Sampling frequency
ADC1206S040	Single 12 bits ADC	<a href="#">[1]</a>	40 MHz
ADC1206S055	Single 12 bits ADC	<a href="#">[1]</a>	55 MHz
ADC1206S070	Single 12 bits ADC	<a href="#">[1]</a>	70 MHz

[1] Pin to pin compatible

### 12.4 Recommended companion chip

The recommended companion chip is the TDA9901 wideband differential digital controlled variable gain amplifier.



### 13. Support information

#### 13.1 Definitions

##### 13.1.1 Non-linearities

###### 13.1.1.1 Integral Non-Linearity (INL)

It is defined as the deviation of the transfer function from a best fit straight line (linear regression computation). The INL of the code  $i$  is obtained from the equation:

$$INL(i) = \frac{V_I(i) - V_I(ideal)}{S} \tag{1}$$

where  $i = 0 \cdot (2^n - 1)$  and

$S$  = slope of the ideal straight line = code width;  $i$  = code value.

###### 13.1.1.2 Differential Non-Linearity (DNL)

It is the deviation in code width from the value of 1 LSB.

$$DNL(i) = \frac{V_I(i+1) - V_I(i)}{S} - 1 \tag{2}$$

where  $i = 0 \cdot (2^n - 2)$

##### 13.1.2 Dynamic parameters (single tone)

Figure 26 shows the spectrum of a full-scale input sine wave with frequency  $f_t$ , conforming to coherent sampling ( $f_t / f_s = M / N$ , where  $M$  is the number of cycles and  $N$  is number of samples,  $M$  and  $N$  being relatively prime), and digitized by the ADC under test.

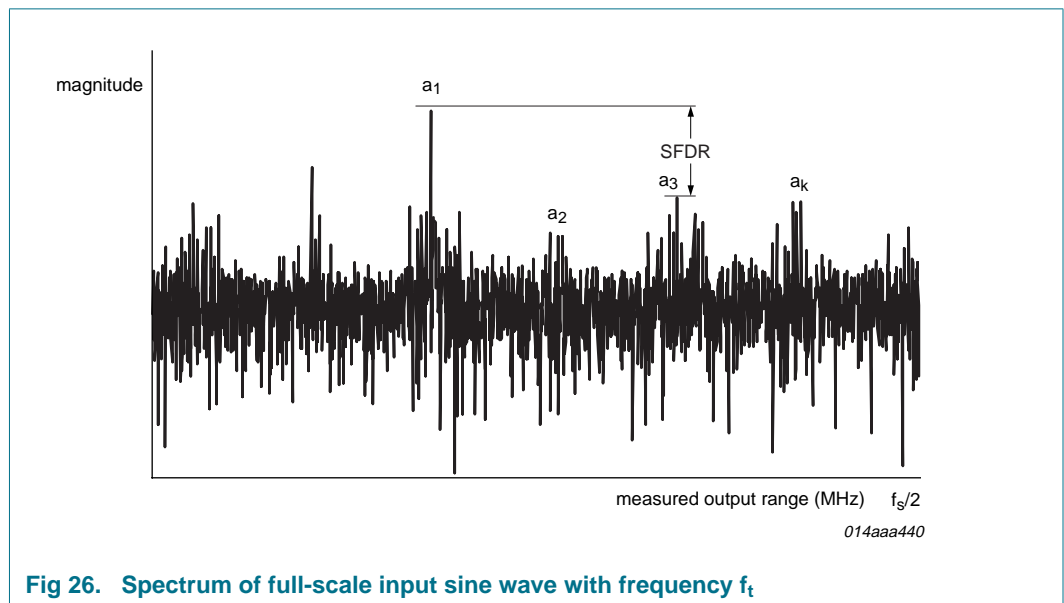


Fig 26. Spectrum of full-scale input sine wave with frequency  $f_t$

**Remark:** In the following equations,  $P_{noise}$  is the power of the terms which include the effects of random noise, non-linearities, sampling time errors, and ‘quantization noise’.

**13.1.2.1 Signal-to-Noise And Distortion (SINAD)**

The ratio of the output signal power to the noise and distortion power for a given sample rate and input frequency, excluding the DC component:

$$SINAD [dB] = 10 \log \left[ \frac{P_{signal}}{P_{noise + distortion}} \right] \tag{3}$$

**13.1.2.2 Effective Number Of Bits (ENOB)**

It is derived from SINAD and gives the theoretical resolution an ideal ADC would require to obtain the same SINAD measured on the real ADC. A good approximation gives:

$$ENOB = (SINAD [dB] - (1.76)) / (6.02)$$

**13.1.2.3 Total Harmonic Distortion (THD)**

The ratio of the power of the harmonics to the power of the fundamental. For k-1 harmonics the THD is:

$$THD [dB] = 10 \log \left[ \frac{P_{harmonics}}{P_{signal}} \right] \tag{4}$$

where  $P_{harmonics} = \alpha_2^2 + \alpha_3^2 + \alpha_k^2$  and  $P_{signal} = \alpha_1^2$

The value of k is usually 6 (i.e. calculation of THD is done on the first 5 harmonics).

**13.1.2.4 Signal-to-Noise ratio (S/N)**

The ratio of the output signal power to the noise power, excluding the harmonics and the DC component.

$$S/N [dB] = 10 \log \left[ \frac{P_{signal}}{P_{noise}} \right] \tag{5}$$

**13.1.2.5 Spurious Free Dynamic Range (SFDR)**

The number SFDR specifies available signal range as the spectral distance between the amplitude of the fundamental and the amplitude of the largest spurious (harmonic and non-harmonic), excluding DC component.

$$SFDR [dB] = 20 \log \frac{\alpha_1}{max(s)} \tag{6}$$

13.1.3 Intermodulation distortion

13.1.3.1 Spectral analysis (dual-tone)

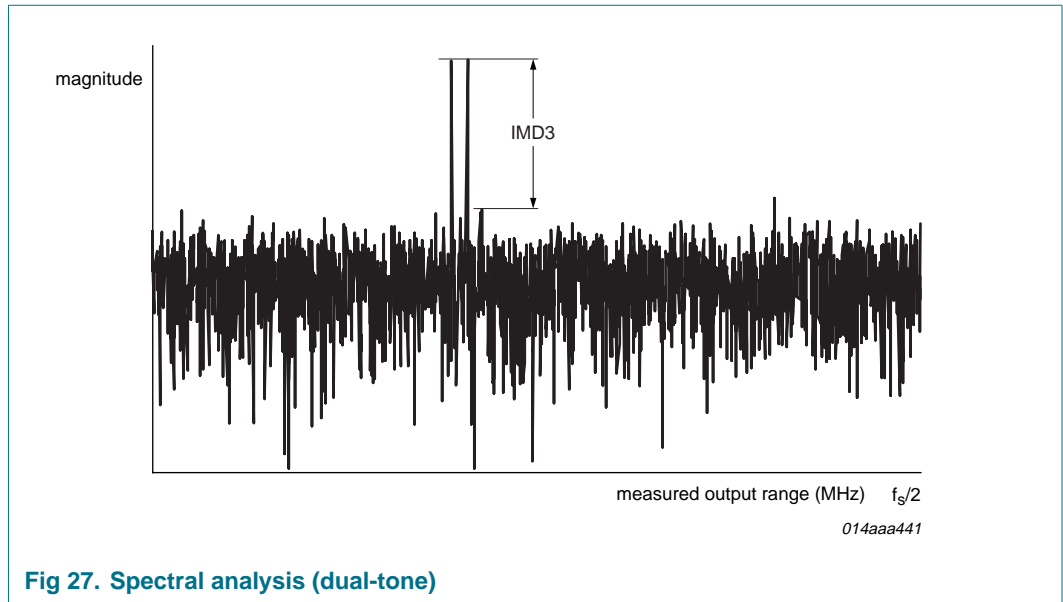


Fig 27. Spectral analysis (dual-tone)

From a dual-tone input sinusoid ( $f_{t1}$  and  $f_{t2}$ , these frequencies being chosen according to the coherence criterion), the intermodulation distortion products IMD2 and IMD3 (respectively, 2nd and 3rd-order components) are defined, as follows.

13.1.3.2 IMD2 (IMD3)

The ratio of the RMS value of either tone to the RMS value of the worst second (third) order intermodulation product.

The total IMD is given by:

$$IMD [dB] = 10 \log \left[ \frac{P_{intermod}}{P_{signal}} \right]$$

where,

$$P_{intermod} = a_{im}^2(f_{t1} - f_{t2}) - a_{im}^2(f_{t1} + f_{t2}) + a_{im}^2(f_{t1} - 2f_{t2}) + a_{im}^2(f_{t1} + 2f_{t2}) + a_{im}^2(2f_{t1} - f_{t2}) + a_{im}^2(2f_{t1} + f_{t2})$$

$$P_{signal} = a^2(f_{t1}) + a^2(f_{t2}) \text{ and}$$

$a_{im}^2(f_t)$  is the power in the intermodulation component at frequency  $f_t$ .

13.1.4 Noise Power Ratio (NPR)

When using a notch-filtered broadband white-noise generator as the input to the ADC under test, the NPR is defined as the ratio of the average out-of-notch to the in-notch power spectral density magnitudes for the FFT spectrum of the ADC output sample set.

14. Package outline

QFP44: plastic quad flat package; 44 leads (lead length 1.3 mm); body 10 x 10 x 1.75 mm

SOT307-2

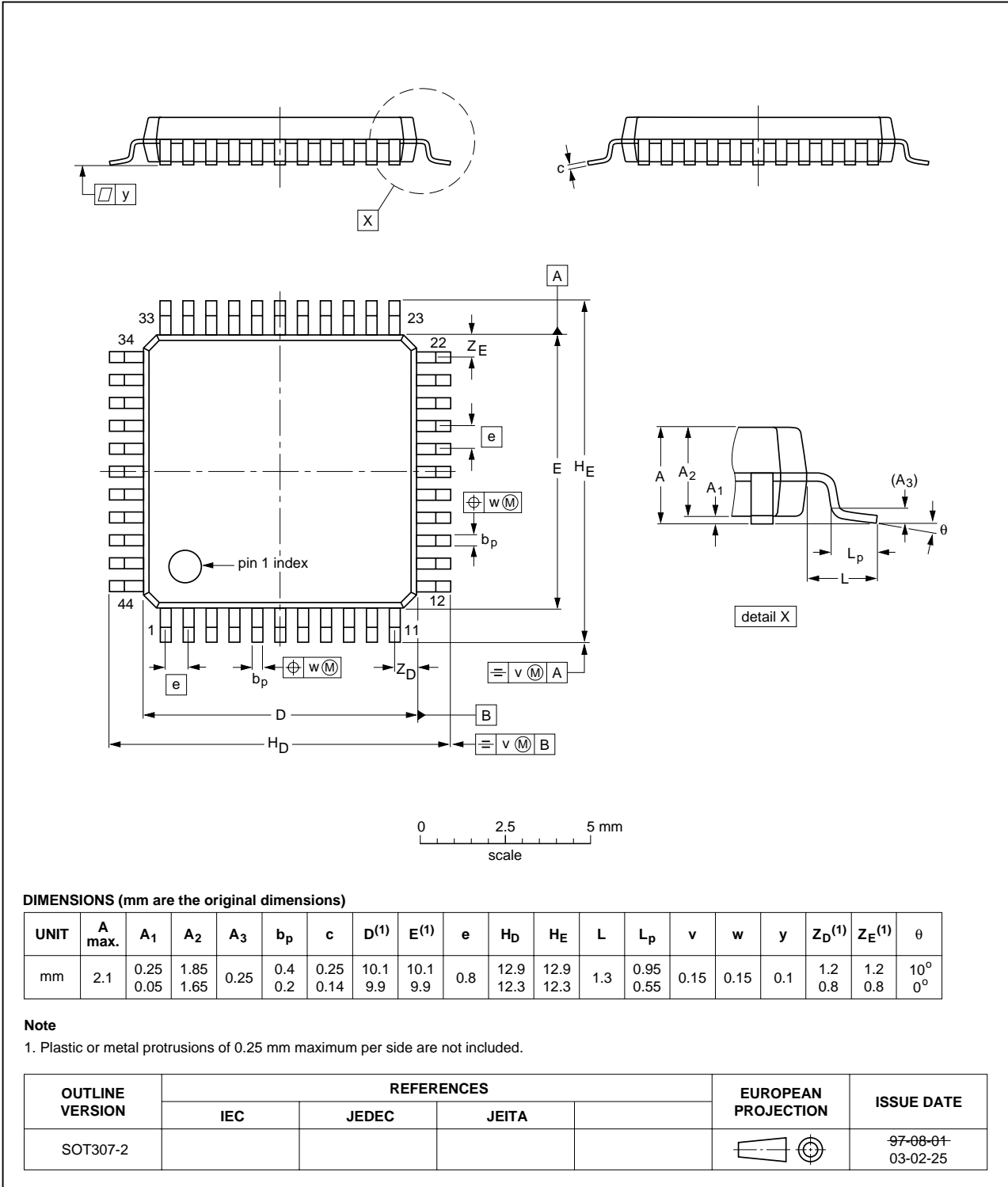


Fig 28. Package outline SOT307-2 (QFP44)

## 15. Revision history

Table 11. Revision history

Document ID	Release date	Data sheet status	Change notice	Supersedes
ADC1006S055_070_2	20080812	Product data sheet	-	ADC1006S055_070_1
Modifications:	<ul style="list-style-type: none"><li>• Corrections made to titles in <a href="#">Figure 13</a> and <a href="#">14</a>.</li><li>• Corrections made to note in <a href="#">Figure 4</a>.</li></ul>			
ADC1006S055_070_1	20080611	Product data sheet	-	-

## 16. Legal information

### 16.1 Data sheet status

Document status <sup>[1][2]</sup>	Product status <sup>[3]</sup>	Definition
Objective [short] data sheet	Development	This document contains data from the objective specification for product development.
Preliminary [short] data sheet	Qualification	This document contains data from the preliminary specification.
Product [short] data sheet	Production	This document contains the product specification.

[1] Please consult the most recently issued document before initiating or completing a design.

[2] The term 'short data sheet' is explained in section "Definitions".

[3] The product status of device(s) described in this document may have changed since this document was published and may differ in case of multiple devices. The latest product status information is available on the Internet at URL <http://www.nxp.com>.

### 16.2 Definitions

**Draft** — The document is a draft version only. The content is still under internal review and subject to formal approval, which may result in modifications or additions. NXP Semiconductors does not give any representations or warranties as to the accuracy or completeness of information included herein and shall have no liability for the consequences of use of such information.

**Short data sheet** — A short data sheet is an extract from a full data sheet with the same product type number(s) and title. A short data sheet is intended for quick reference only and should not be relied upon to contain detailed and full information. For detailed and full information see the relevant full data sheet, which is available on request via the local NXP Semiconductors sales office. In case of any inconsistency or conflict with the short data sheet, the full data sheet shall prevail.

### 16.3 Disclaimers

**General** — Information in this document is believed to be accurate and reliable. However, NXP Semiconductors does not give any representations or warranties, expressed or implied, as to the accuracy or completeness of such information and shall have no liability for the consequences of use of such information.

**Right to make changes** — NXP Semiconductors reserves the right to make changes to information published in this document, including without limitation specifications and product descriptions, at any time and without notice. This document supersedes and replaces all information supplied prior to the publication hereof.

**Suitability for use** — NXP Semiconductors products are not designed, authorized or warranted to be suitable for use in medical, military, aircraft, space or life support equipment, nor in applications where failure or malfunction of an NXP Semiconductors product can reasonably be expected to result in personal injury, death or severe property or environmental

damage. NXP Semiconductors accepts no liability for inclusion and/or use of NXP Semiconductors products in such equipment or applications and therefore such inclusion and/or use is at the customer's own risk.

**Applications** — Applications that are described herein for any of these products are for illustrative purposes only. NXP Semiconductors makes no representation or warranty that such applications will be suitable for the specified use without further testing or modification.

**Limiting values** — Stress above one or more limiting values (as defined in the Absolute Maximum Ratings System of IEC 60134) may cause permanent damage to the device. Limiting values are stress ratings only and operation of the device at these or any other conditions above those given in the Characteristics sections of this document is not implied. Exposure to limiting values for extended periods may affect device reliability.

**Terms and conditions of sale** — NXP Semiconductors products are sold subject to the general terms and conditions of commercial sale, as published at <http://www.nxp.com/profile/terms>, including those pertaining to warranty, intellectual property rights infringement and limitation of liability, unless explicitly otherwise agreed to in writing by NXP Semiconductors. In case of any inconsistency or conflict between information in this document and such terms and conditions, the latter will prevail.

**No offer to sell or license** — Nothing in this document may be interpreted or construed as an offer to sell products that is open for acceptance or the grant, conveyance or implication of any license under any copyrights, patents or other industrial or intellectual property rights.

**Quick reference data** — The Quick reference data is an extract of the product data given in the Limiting values and Characteristics sections of this document, and as such is not complete, exhaustive or legally binding.

### 16.4 Trademarks

Notice: All referenced brands, product names, service names and trademarks are the property of their respective owners.

## 17. Contact information

For more information, please visit: <http://www.nxp.com>

For sales office addresses, please send an email to: [salesaddresses@nxp.com](mailto:salesaddresses@nxp.com)

## 18. Contents

<b>1</b>	<b>General description</b> . . . . .	<b>1</b>
<b>2</b>	<b>Features</b> . . . . .	<b>1</b>
<b>3</b>	<b>Applications</b> . . . . .	<b>1</b>
<b>4</b>	<b>Quick reference data</b> . . . . .	<b>2</b>
<b>5</b>	<b>Ordering information</b> . . . . .	<b>2</b>
<b>6</b>	<b>Block diagram</b> . . . . .	<b>3</b>
<b>7</b>	<b>Pinning information</b> . . . . .	<b>4</b>
7.1	Pinning . . . . .	4
7.2	Pin description . . . . .	4
<b>8</b>	<b>Limiting values</b> . . . . .	<b>5</b>
<b>9</b>	<b>Thermal characteristics</b> . . . . .	<b>6</b>
<b>10</b>	<b>Characteristics</b> . . . . .	<b>6</b>
<b>11</b>	<b>Additional information relating to <a href="#">Table 6</a></b> . . . . .	<b>12</b>
<b>12</b>	<b>Application information</b> . . . . .	<b>19</b>
12.1	Application diagrams . . . . .	19
12.2	Demonstration board . . . . .	21
12.3	Alternative parts . . . . .	24
12.4	Recommended companion chip . . . . .	24
<b>13</b>	<b>Support information</b> . . . . .	<b>25</b>
13.1	Definitions . . . . .	25
13.1.1	Non-linearities . . . . .	25
13.1.1.1	Integral Non-Linearity (INL) . . . . .	25
13.1.1.2	Differential Non-Linearity (DNL) . . . . .	25
13.1.2	Dynamic parameters (single tone) . . . . .	25
13.1.2.1	Signal-to-Noise And Distortion (SINAD) . . . . .	26
13.1.2.2	Effective Number Of Bits (ENOB) . . . . .	26
13.1.2.3	Total Harmonic Distortion (THD) . . . . .	26
13.1.2.4	Signal-to-Noise ratio (S/N) . . . . .	26
13.1.2.5	Spurious Free Dynamic Range (SFDR) . . . . .	26
13.1.3	Intermodulation distortion . . . . .	27
13.1.3.1	Spectral analysis (dual-tone) . . . . .	27
13.1.3.2	IMD2 (IMD3) . . . . .	27
13.1.4	Noise Power Ratio (NPR) . . . . .	27
<b>14</b>	<b>Package outline</b> . . . . .	<b>28</b>
<b>15</b>	<b>Revision history</b> . . . . .	<b>29</b>
<b>16</b>	<b>Legal information</b> . . . . .	<b>30</b>
16.1	Data sheet status . . . . .	30
16.2	Definitions . . . . .	30
16.3	Disclaimers . . . . .	30
16.4	Trademarks . . . . .	30
<b>17</b>	<b>Contact information</b> . . . . .	<b>30</b>
<b>18</b>	<b>Contents</b> . . . . .	<b>31</b>

Please be aware that important notices concerning this document and the product(s) described herein, have been included in section 'Legal information'.

founded by

**PHILIPS**

© NXP B.V. 2008.

All rights reserved.

For more information, please visit: <http://www.nxp.com>

For sales office addresses, please send an email to: [salesaddresses@nxp.com](mailto:salesaddresses@nxp.com)

Date of release: 12 August 2008

Document identifier: ADC1006S055\_070\_2